

Quick Start Guide

MB10-VL

Version: 1.1

enlaces
del caribe
inteligencia en seguridad

1. Overview

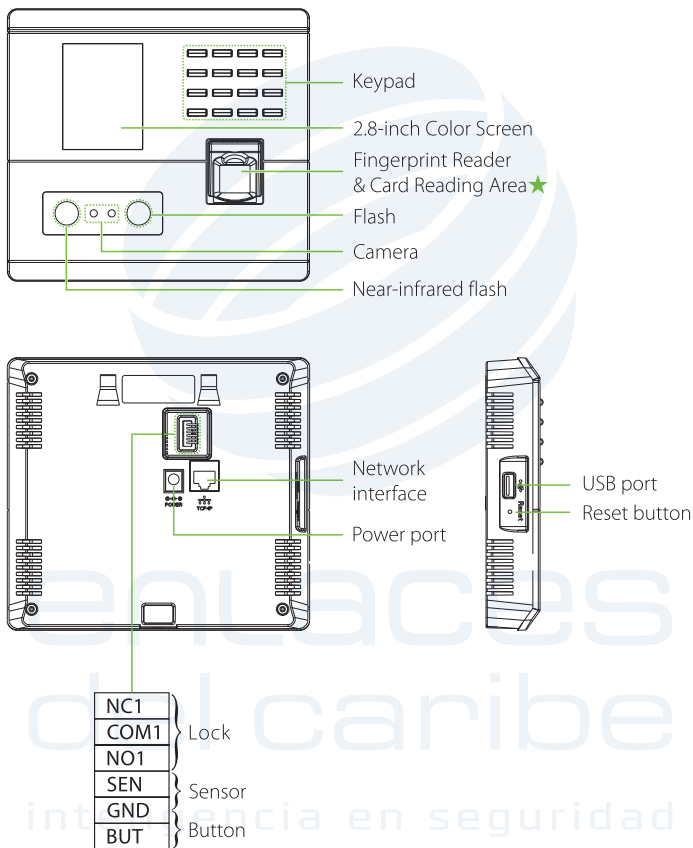

Note: Features and parameters with ★ mark are not available in all devices.

2. Device Installation

❖ Install on the wall

- ① Attach the mounting template sticker to the wall, and drill holes according to the mounting paper.
- ② Fix the back plate on the wall using wall mounting screws.
- ③ After passing the wires through the wiring hole and connecting them to the device, and then attach the device to the back plate from top to bottom.
- ④ Fasten the device to the back plate with a security screw.

1

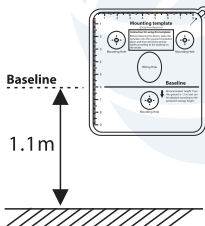

2

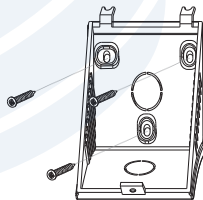

3

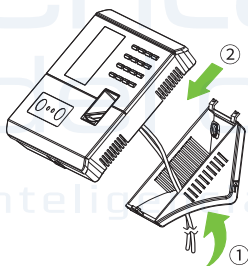

4

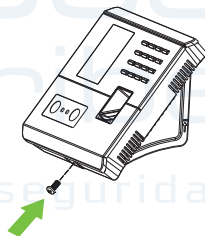

3. Standalone Installation

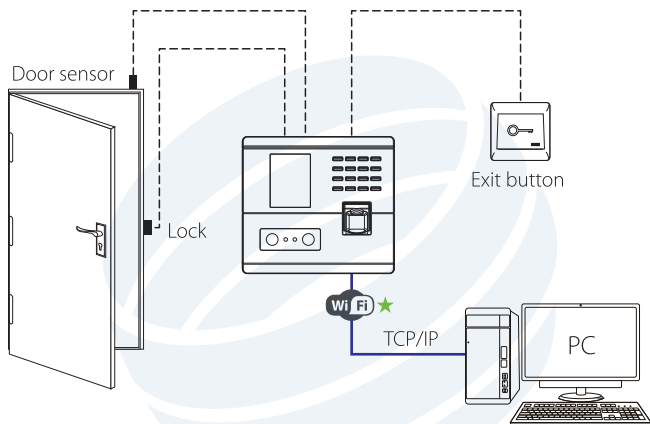

4. Door Sensor & Exit Button Connection

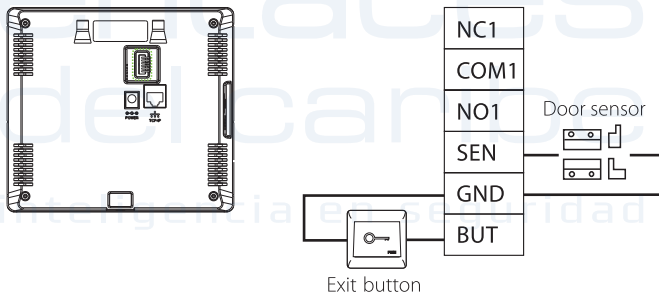

5. Lock Relay Connection

The system supports Normally Opened Lock and Normally Closed Lock. The **NO LOCK** (normally unlocked when powered) is connected with 'NO' and 'COM' terminals, and the **NC LOCK** (normally locked when powered) is connected with 'NC' and 'COM' terminals. Take NC Lock as an example below:

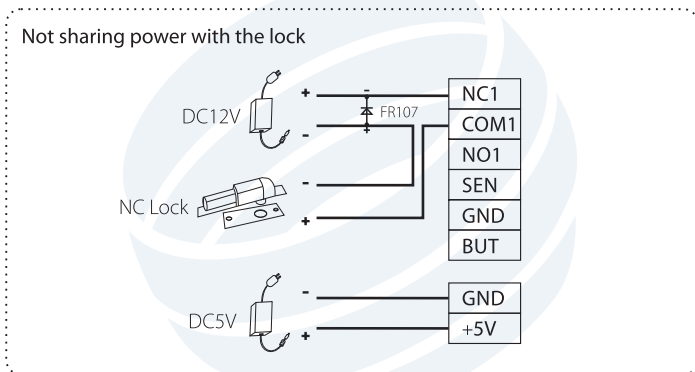

6. Power Connection

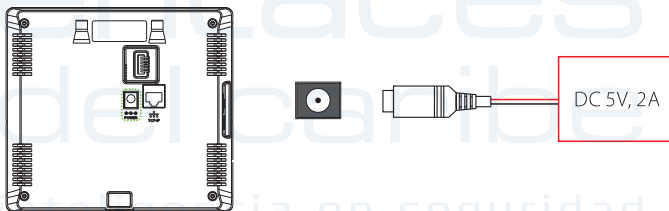

- Recommended AC adapter: **5V, 2A**
- To share the power with other devices, use an AC adapter with higher current ratings.

7. Ethernet Connection

Connect the device and computer software over an Ethernet cable. As shown in the example below:



Default IP address: 192.168.1.201
Subnet mask: 255.255.255.0



IP address: 192.168.1.130
Subnet mask: 255.255.255.0

Click on **[Comm.] > [Ethernet] > [IP Address]**, input the IP address and click on **[OK]**.

Note: In LAN, the IP addresses of the server (PC) and the device must be in the same network segment while connecting to the ZKBioAccess IVS software.

8. Quick Start

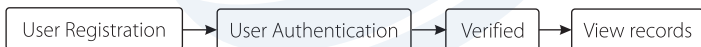

User registration

Method 1: Registering on the device

Press **[M/OK] > [Main Menu] > [User Mgt.] > [New User]**. Enter User ID, Name, User Role, Department, Verification Mode and register Face, Fingerprint, Card Number★ and Password, to register a user.

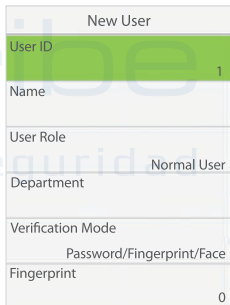
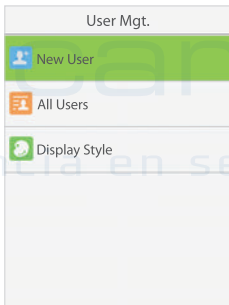
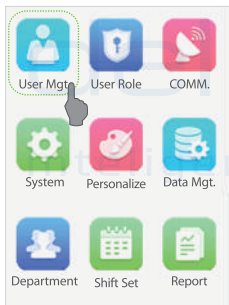

Method 2: Registering on the software (ZKBioAccess IVS)

Please set the IP address and cloud service server address in the Comm. Menu option on the device.

1. Click **[Attendance]** > **[Attendance Device]** > **[Device]** > **[Search]** to search the device on the software. When an appropriate server address and port is set on the device, the searched devices are displayed automatically.

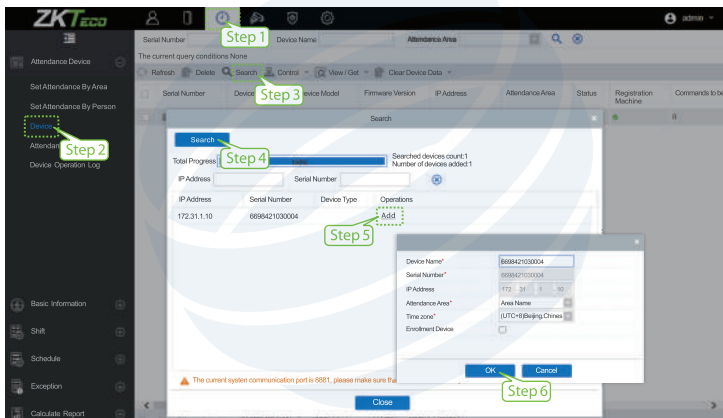

2. Click **[Add]** in operation column, a new window will pop-up. Select Attendance Area and Time zone from each dropdowns and click **[OK]** to add the device.
3. Click **[Personnel]** > **[Person]** > **[New]** and fill in all the required fields to register a new users in the software.
4. Click **[Attendance Device]** > **[Device]** > **[Control]** > **[Synchronize Software Data to the Device]** to synchronize all the data to the device including the new users. For more details, please refer to the ZKBioAccess IVS User Manual.

Method 3: Registering on the phone

Once the ZKBioAccess IVS software is installed, the users could enroll their face via a browser application on their own mobile phone.

1. Click **[Personnel]** > **[Parameters]**, input "**http://Server address: Port**" in the QR Code UGL bar. The software will automatically generate a QR code. Scan the QR code or login onto "**http://Server address: Port/app/v1/adreg**" by the mobile phone to register users.

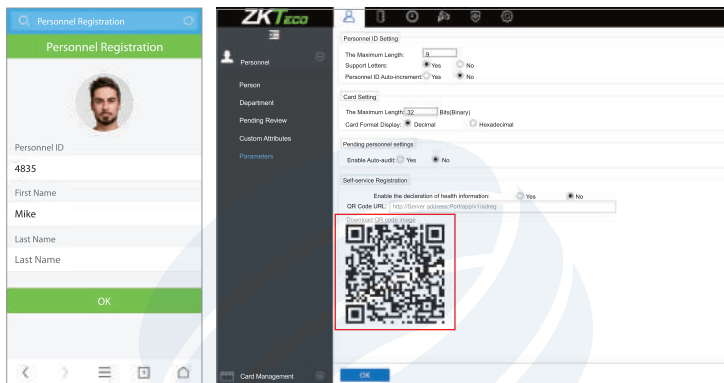

2. The users will be displayed in [Personnel] > [Pending Review], click on [Review] option and assign a department and click [OK] to successfully add the user.

User Authentication

The terminal can detect the face within a range of 0.3m to 1.5m. The device switches to the face verification interface automatically once it detects a change in environmental brightness. The verification result shows the registered image and personnel details.

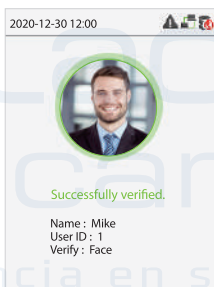

View records

View records on the software

Click [Device] > [Data] > [Transaction] on the software to view the records.

9. Access Control Settings

Press [M/OK] > [Access Control] to enter the access control management interface and set relevant parameters of access control.

Access Control	
Access Control Options	

Access Control Options	
Door Lock Delay (s)	10
Door Sensor Delay (s)	10
Door Sensor Type	Normal Close (NC)
Door Alarm Delay (s)	30
Speaker Alarm	<input type="checkbox"/>

10. Ethernet and Cloud Server Settings

Press [M/OK] > [Comm.] > [Ethernet] to set the network parameters. If the TCP/IP communication of the device is successful, the icon  will be displayed in the upper right corner of the standby interface.

Press [M/OK] > [Comm.] > [Cloud Server Setting] to set the server address and server port, that is, the IP address and port number of the server after the software is installed. If the device communicates with the server successfully, the icon  will be displayed in the upper right corner of the standby interface.

Ethernet	
IP Address	192.168.1.201
Subnet Mask	255.255.255.0
Gateway	0.0.0.0
DNS	0.0.0.0
TCP COMM. Port	4370
DHCP	<input type="checkbox"/>

Cloud Server Setting	
Server Mode	ADMS
Enable Domain Name	<input type="checkbox"/>
Server Address	0.0.0.0
Server Port	8081
Enable Proxy Server	<input type="checkbox"/>
HTTPS	<input type="checkbox"/>



enlaces

del caribe

ZKTeco Industrial Park, No. 32, Industrial Road,

Tangxia Town, Dongguan, China.

Phone : +86 769 - 82109991

Fax : +86 755 - 89602394

www.zkteco.com

